

Agenda

B Ward Committee Meeting **18 May 2026**

A B Ward Committee Meeting will be held in the Ballina Shire Council Chambers, 40 Cherry Street, Ballina on **18 May 2026 commencing at 4:30 PM.**

1. Acknowledgment of Country
2. Attendance and Apologies (including updates/changes in membership)
3. Declarations of Interest
4. Presentations
5. Confirmation of Minutes – Monday, 16 March 2026
6. Business Arising from Minutes - Monday, 16 March 2026
7. Business With Notice
8. General Business
9. Business Without Notice
10. Council Documents on Exhibition
11. Next Meeting/Future Meeting Dates
12. Meeting Closure

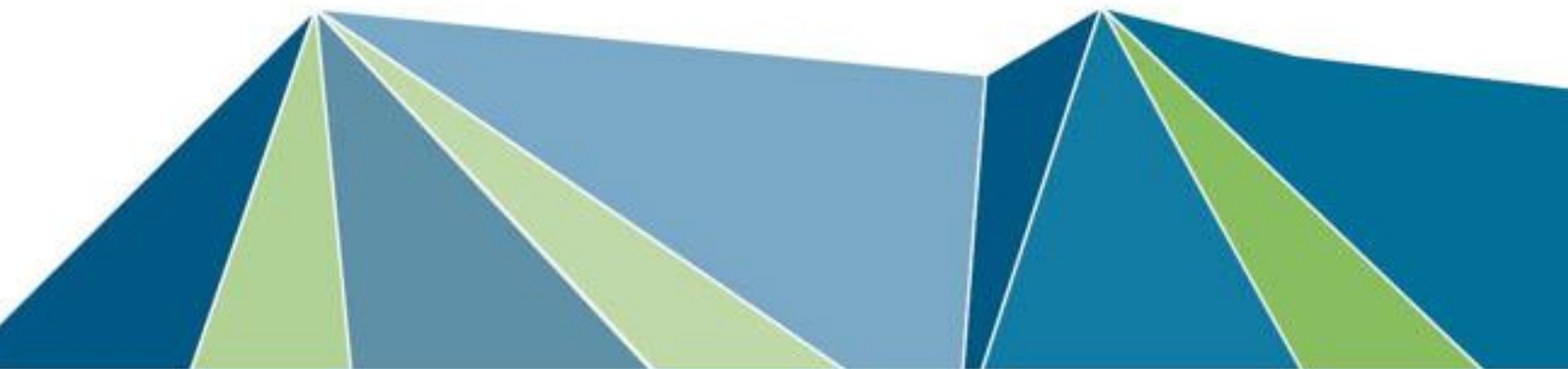

Table of Contents

1.	Acknowledgment of Country	3
2.	Attendance and Apologies (including updates/changes in membership).....	3
3.	Declarations of Interest.....	3
4.	Presentations	3
5.	Confirmation of Minutes.....	3
6.	Business Arising from Minutes.....	4
6.1	Business Arising from Minutes of 16 March 2026 - Lennox Head Residents' Association (LHRA) - Additional Shared Zone Signage	4
6.2	Business Arising from Minutes of 16 March 2026 - Ballina Environment Society (BES) - Ballina War Memorial Pool Facility Improvement - Dishwasher	5
7.	General Business	7
7.1	Vale to Marine Rescue Volunteers	7
8.	Business With Notice.....	8
8.1	Business With Notice - Lennox Head Residents' Association - Lake Ainsworth Water Quality	8
8.2	Business With Notice - Ballina Environment Society - Climate Change	10
8.3	Business With Notice - Lennox Head Residents' Association - Increased Incidence of Water Bombing in Lennox Head	12
8.4	Business With Notice - Lennox Head Residents' Association - Rubber Traffic Calmers in Park Lane	13
9.	Business Without Notice.....	14
10.	Council Documents on Exhibition	15
10.1	Council Documents on Exhibition	15
11.	Next Meeting / Future Meeting Dates	16
12.	Meeting Closure	16

DISCLAIMER ©NSW Spatial Services 2024. Although all care is taken in the preparation of plans within Council's business paper (both agendas and attachments), Ballina Shire Council accepts no responsibility for any misprints, error, omissions or inaccuracies. The information contained within each plan is for pictorial representation only and not to scale. Accurate measurements should be undertaken by survey.

1. Acknowledgment of Country
 2. Attendance and Apologies (including updates/changes in membership)
 3. Declarations of Interest
 4. Presentations
 5. Confirmation of Minutes
-

1. Acknowledgment of Country

In opening the meeting, the Chair will provide an Acknowledgement of Country.

We acknowledge the Nyangbul peoples of the Bundjalung nation, the traditional custodians of the land on which we meet today and pay our respects to their Elders, past and present.

2. Attendance and Apologies (including updates/changes in membership)

3. Declarations of Interest

4. Presentations

5. Confirmation of Minutes

A copy of the Minutes of the B Ward Committee Meeting held on Monday 16 March 2026 was distributed.

RECOMMENDATION

Minutes of the B Ward Committee Meeting held on Monday 16 March 2026 be confirmed.

6.1 Business Arising from Minutes of 16 March 2026 - Lennox Head Residents' Association (LHRA) - Additional Shared Zone Signage

6. Business Arising from Minutes

6.1 Business Arising from Minutes of 16 March 2026 - Lennox Head Residents' Association (LHRA) - Additional Shared Zone Signage

Lennox Head Residents' Association further discussed whether it was possible to add additional signage to the right-hand turn in Raynor Lane adjacent to Ross Park, further to the existing shared zone signs at each end of the Lane.

Action: To be referred to Engineering Works section to review request for additional shared zone signage.

Staff comment:

Engineering Works have reviewed the signage at the site and confirmed that the change in pavement types and existing signage is compliant with standards and adequate to support the operation of the one-way lane.

Attachment(s)

Nil

6.2 Business Arising from Minutes of 16 March 2026 - Ballina Environment Society (BES) - Ballina War Memorial Pool Facility Improvement - Dishwasher

6.2 Business Arising from Minutes of 16 March 2026 - Ballina Environment Society (BES) - Ballina War Memorial Pool Facility Improvement - Dishwasher

Ballina Environment Society raised that the Ballina War Memorial Pool managers have identified the need for a dishwasher at the facility. It was suggested this matter be forwarded to Council's grants team to provide information on applicable grant funding opportunities available.

Action: Refer to Council's Manager Facilities and Services to review provision of a dishwasher at the Ballina War Memorial Pool.

Staff comment:

Council staff have investigated the provision of dishwashers for both Ballina and Alstonville Pools

Dishwashers suitable for commercial applications differ significantly from standard domestic units used in residential situations. Commercial dishwashers typically operate at higher wash temperatures and faster cycle times and are designed to meet food safety and operational requirements for high-use environments.

The commercial dishwasher identified as suitable for both facilities is specifically designed for use with reusable cups. The supply-only cost for this unit is \$13,900 per dishwasher.

In addition, significant work would be required to support installation at both facilities including upgrades to water supply and drainage infrastructure, as well as modifications to existing benches to accommodate the unit. The estimated cost of these associated works is in the order of \$5,000-\$6,000.

The manufactures brochure is attached for reference.

6.2 Business Arising from Minutes of 16 March 2026 - Ballina Environment Society (BES) - Ballina War Memorial Pool Facility Improvement - Dishwasher

HOBART

FP - PREMAX DISHWASHER



PRODUCT ADVANTAGES

- **Optional CUTLERY PREMIUM:** The innovative system ensures clean and shiny cutlery without polishing. The program is selected automatically by the machine
- **TOP-DRY:** integrated drying technology - no need for manual drying
- **VAPOSTOP²:** allows door opening without steam cloud. Also prevents steam escape during the drying phase
- **Self-cleaning wash system:** The combined wash and rinse system features innovative self-cleaning of the wash arms with every cycle. This saves time and ensures a perfect cleaning result
- **VISIOTRONIC-TOUCH control:** colour touchscreen (displays text and graphic) in conjunction with single-button control and remaining cycle time indication
- **SmartConnect app:** controlling your warewash operation with smart technology; status and messages, usage and operating costs, hygiene and service
- **Eco programme:** switchable steam rinse cycle reduces fresh-water consumption to 0.8 l. Saving of up to 60 % water and chemicals
- **SENSO-ACTIVE resource management:** constantly measures the quality of the wash water and keeps the amount of rinsing needed in each rinse cycle to the minimum
- **Optional 2IN1 double rack system:** two racks can be washed in a single wash cycle. Thanks to the optimum use of the entire wash chamber the performance of the machine can be doubled
- **CLIP-IN wash and rinse system:** easy removal without any tools
- **Intelligent data documentation:** automatic recording of important operational data and consumptions and indication on the display
- **USB-interface:** comfortable download of operational data in form of a protocol via USB
- **GENIUS-X² fine filter system:** advanced filter system with pre-wash function reduces detergent consumption up to 35 %
- **Interlocked strainer:** prevents operation without tank strainer
- **Optional refill signal:** monitors contents of external as well as integrated chemical containers
- **Hygiene programme (in combination with Hygiene-Tab INTENSIV)** for removal of calcium carbonate and other deposits from wash chamber
- **Thermolabel 71 °C:** default temperatures setting acc. European DIN can be switched by operator to a higher thermolabel setting
- **WATERMARK APPROVED**

TECHNICAL DATA

Cycle times*	1. 80sec 2. 150sec 3.170sec & specialty cycles
Water consumption	0.8 l/rack
Tank capacity	10.6 l
Tank heating	1.7 kW
Power supply	415 / 50 / 3N (240 / 50 / 1)
Booster loading	
Standard	6.1 kW
Alternative	2.0 kW
Total loading	
Standard	6.7 kW 3 x 15 A
Alternative	3.2 kW 15 A
Wash pump	0.5 kW 350 l/min
Rack size	500 x 500
Loading height	425 mm
Noise level	60.5 dB (A)
Weight (gross / net)	70 / 60 kg

*Thermosop guarantees required temperatures with cold water connection and / or 240V connection, the actual cycles times extend accordingly, the actual cycle times extend accordingly. For machine protection the water hardness should not exceed 3°dH, if higher we recommend using an integrated water softener or an external water softener of the product line HYDROLINE PROTECT. To avoid spots and streaks on the wash ware, we recommend the usage of a demineralisation cartridge or a reverse osmosis system HYDROLINE PURE.

CONNECTIONS

① Drain hose	2,000 mm ID20/OD25
Reverse Osmosis unit (RO-S)	Independent gravity waste to tundish
② Supply hose	2,000 mm R 3/4"
Required flow rate	5 l/min
Flow pressure	0.5 (0.8 with softener)- 6 bar
Max. supply water temperature	60 °C 35 °C With RO-S
③ Power cord	2,000 mm
Supply hose for	
④ Detergent	2,500 mm
⑤ Rinse aid	2,500 mm

DIMENSIONAL DRAWING

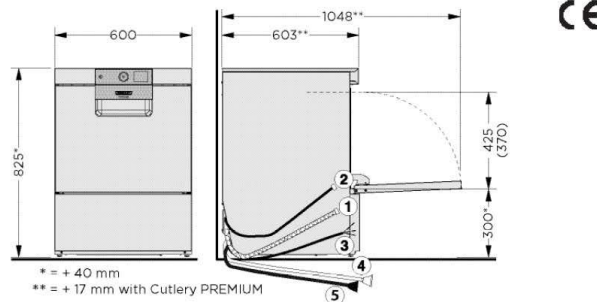

14

EFFECTIVE: 01 August 2024

Attachment(s)

Nil

7.1 Vale to Marine Rescue Volunteers

7. General Business

7.1 Vale to Marine Rescue Volunteers

Vale Frank Petsch and Bill Ewen, our heroic Marine Rescue Volunteers who lost their lives during a rescue on 4 May 2026.

May they continue to be honoured and acknowledged for their bravery and contribution to the community.

It is proposed the committee observes one minute's silence.

Attachment(s)

Nil

8.1 Business With Notice - Lennox Head Residents' Association - Lake Ainsworth Water Quality

8. Business With Notice

8.1 Business With Notice - Lennox Head Residents' Association – Lake Ainsworth Water Quality

Narissa Phelps from Lennox Head Residents' Association requested an update on the most recent water quality results and sediment tests at Lake Ainsworth and submitted the following:

Health of Lake Ainsworth - health issues to users of the lake.

A Lake Ainsworth Interest Group was established with Lennox Head Residents' Association as one of the members. A short term, medium term and a long term action plan was agreed upon to report on matters, including 'the altered lake hydrology due to sediment build-up of nutrient rich muds, acidic and oxygen deficient high Organic Carbon.'

Has LHRA received any reports on the health of the lake in particular in regard to the nutrient enrichment and microbiological risk to human health? This report is due for the medium-term action plan period 2023 – 2026.

1. When was the last time tests were carried out on the water and the sediment muds?

Connected to these concerns I suggest Council install more showers for people to rinse off the lake water especially for young children due to the risks of skin and eye infections.

Staff Comment:

Lake Ainsworth Coastal Management Program 2020 update.

In 2020 Council successfully completed the [Lake Ainsworth Coastal Management Program](#) following extensive and valuable community consultation. The CMP identified twenty-nine actions to be implemented over the 10-year life of the CMP. These actions covered water quality matters, litter improvements, aquatic weed management, public access and many other issues important to managing the Lake.

Since the certification of the CMP Council has progressively implemented the actions as funds have become available through grant funding or other funding sources. Fourteen actions have been completed and another four are noted as either ongoing or progressing.

In relation to the nutrient rich muds present in the Lake this matter was extensively studied during the detailed studies phase of the CMP development, so we have a very good understanding of the current situation in relation to the mud present and interactions with the water quality of the Lake.

Action 1 of the CMP was to trial the use of the aerator to optimise its use and determine if the action 2 trial of sediment treatments may be required. The two phases of the aerator trial determined that 24 hours per day operation of the aerator was optimal and very effective in preventing nutrients from mobilising from the mud into the water column. Therefore, we have not progressed to

8.1 Business With Notice - Lennox Head Residents' Association - Lake Ainsworth Water Quality

implementing action 2 at this time but are instead moving forward with works to increase the capacity of the aerator to operate 24 hours per day during the peak recreational use periods.

As information and studies have become available Council has published them on our website, promoted through Community Connect and placed signs at the site.

The detailed studies phase of the CMP and the two reports assessing the effectiveness of the aerator involved very detailed studies of the processes within the Lake. These can be made available on request when not currently on our website. In addition, Council undertakes other routine sampling programs at the Lake with Beachwatch samples being collected 5/month during December – February providing the community advice on the health risks associated with swimming.

Project details are available here:
<https://www.ballina.nsw.gov.au/Environment/Beaches-and-Waterways/Beach-Health>

Information on sampling from October - April to monitor blue-green algal levels and provide guidance to the public is available here:
<https://www.ballina.nsw.gov.au/Environment/Beaches-and-Waterways/Lake-Ainsworth-Blue-Green-Algae-Status>

Attachment(s)

Nil

8.2 Business With Notice - Ballina Environment Society - Climate Change

8.2 Business With Notice - Ballina Environment Society - Climate Change

Ballina Environment Society (BES) submitted the following item and questions.

BES appreciates the attention given by Ballina Shire Council in developing a Climate Change Policy illustrating the enormity of applying numerous short term, medium term and long term strategies required to achieve Net Zero Emissions' targets by 2030 and 2050.

1. Will Council maintain its Net Zero Emissions target (2015 Paris Agreement) and ignore the abandonment of Net Zero policies by the National, Liberal and One Nation political parties?

Staff Comment:

Council is currently in the process of a periodic review of its Climate Change Policy. The Climate Change Policy was recently placed on public exhibition for community comment and will be reported back to Council for consideration at its May 2026 Council meeting.

The draft policy includes the previously endorsed target of achieving net zero emissions by 2030 for Council operations.

Council's emissions targets and associated implementation measures are determined through its own policy and governance processes and are reviewed periodically to ensure they remain achievable, evidence-based and aligned with Council's strategic objectives.

2. The post-periods of the six major Oil Shocks between 1956 to 2022 saw economies returning to a reliance on petrol, gas and diesel for transport. Since 2020 the enormous advances in renewable energy technology (especially PV Solar and batteries) and the lessons learned from the current Middle Eastern conflicts has given Ballina and the world an opportunity to divert from fossil fuel reliance for energy provision.

Questions arising from Ballina Shire Council Climate Policy strategies in relation to electrification are:

- a) Will conversion to an EV Fleet of vehicles reduce costs of operation and maintenance and have a positive effect on Council finances?

Staff Comment:

Council has an adopted Corporate Emissions Reduction Plan (CERP) that outlines a clear, staged pathway to reach this target. The plan focuses on reducing emissions from Council operations through energy efficiency, renewable energy, fleet transition, and improved operational practices.

The CERP includes an action to develop an Electric Vehicle (EV) Transition Strategy. This work will assess whole-of-life costs, operational suitability, charging infrastructure requirements and financial costs.

8.2 Business With Notice - Ballina Environment Society - Climate Change

Evidence from local government trials and industry data indicates that EVs generally offer lower running costs, reduced maintenance requirements due to fewer moving parts, greater cost certainty when paired with renewable electricity. However, Council acknowledges that not all fleet uses are currently commercially feasible or available. A staged transition will be pursued to ensure operational efficiency and financial viability.

b) Is Council entering into any Power Purchasing Agreements?

Staff Comment:

As part of implementing its emissions reduction actions, Council has entered into a Power Purchase Agreement that supplies 100% renewable electricity for large Council sites and 50% renewable electricity for smaller sites. This arrangement significantly reduces emissions from Council's electricity use and provides long-term price stability.

c) Is Council considering Virtual Power Plant joint ventures?

Staff Comment:

Council is aware of the growing role of Virtual Power Plants (VPP) in supporting energy resilience, peak demand management and increased use of distributed renewable energy. While Council does not currently operate a VPP, this concept may be explored in the future as part of broader renewable energy, battery storage and electrification planning, subject to feasibility, regulatory settings and resource considerations.

In addition, Council is an active member of the Joint Organisation Net-Zero Accelerator (JONZA) program of Northern NSW Councils, which enables regional collaboration on renewable energy initiatives, emissions reduction strategies and emerging technologies, including opportunities that may not be viable for councils acting independently.

Attachment(s)

Nil

8.3 Business With Notice - Lennox Head Residents' Association - Increased Incidence of Water Bombing in Lennox Head

8.3 Business With Notice - Lennox Head Residents' Association – Increased Incidence of Water Bombing in Lennox Head

Lennox Head Residents' Association raised concern regarding an increase in reported incidences of water bombing in Lennox Head. The LHRA noted they have been liaising with NSW Police on the matter.

Staff Comment:

NSW Police is the appropriate agency responsible for investigating and managing matters of this nature. Incidents should be reported directly to NSW Police as Council has no enforcement role in relation to these matters.

Attachment(s)

Nil

8.4 Business With Notice - Lennox Head Residents' Association - Rubber Traffic Calmers in Park Lane

8.4 Business With Notice - Lennox Head Residents' Association - Rubber Traffic Calmers in Park Lane

Lennox Head Residents' Association advised the rubber traffic calmers in Park Lane have deteriorated significantly in the last few months and noted they have raised this issue previously. The LHRA requests that the calmers be repaired.

Staff Comment:

A Customer Request Entry (CRM 164239/2026) has been raised requesting Council staff investigate the condition of the traffic calmers in Park Lane, Lennox Head.

Attachment(s)

Nil

9. Business Without Notice

9. Business Without Notice

Nil Items

10.1 Council Documents on Exhibition

10. Council Documents on Exhibition

10.1 Council Documents on Exhibition

Documents on Exhibition

Documents on public exhibition and Council Notices can be found on our website. A summary is provided below with more information at the following link: [Your Say Ballina](#)

Integrated Planning and Reporting (IP&R) Documents 2026/27 - Submissions close 1 June 2026:

- Draft Delivery Program and Operational Plan 2026/27 – 2029/30
- Draft Long Term Financial Plan 2026/27 – 2035/36
- Draft Fees and Charges 2026/27
- Draft Workforce Management Strategy 2026/27 – 2029/30

IP&R documents can be found at the following link: [Draft plans shaping Ballina Shire now on exhibition | Ballina Shire Council](#)

Community Donations:

- Call for Community Donations for Community Groups – 2026/27 – submissions close 31 May ([Community Donations | Ballina Shire Council](#))

Action Plan:

- [Disability Inclusion Action Plan](#) (review) – submissions close 29 May

Major Projects (not on exhibition):

- Alstonville Cultural Centre Upgrade ([Alstonville Cultural Centre Upgrade](#))
- Bridge Duplications ([Bridge Duplications - Fishery Creek Bridge at West Ballina and Canal Bridge at North Ballina](#))
- Wardell Town Centre Master Plan - Implementation of Stage 2 - Connecting to the River
- River and Martin Street Intersection, Ballina - Roundabout Reconstruction and Improved Paving
- Ross Lane Flood Resilience ([Ross Lane, Flood Resilience](#))

Attachment(s)

Nil

- 11 Next Meeting / Future Meeting Dates
 - 12 Meeting Closure
-

11. Next Meeting / Future Meeting Dates

The next meeting is scheduled for Monday 20 July 2026 at 4:30pm.

Monday 21 September 2026 at 4.30pm

Monday 16 November 2026 at 4.30pm

12. Meeting Closure